

# G600X | Open Set

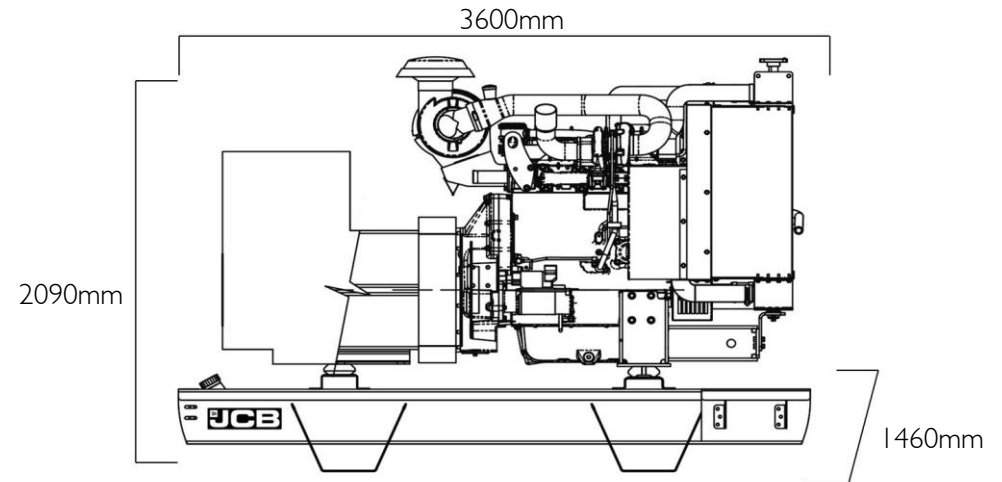

**DIESEL GENERATOR**

**FUEL OPTIMISED**

## ELECTRICAL

Frequency (Hz)	Phases	Voltage (V)	Prime		Standby		MCB Rating (A)	Minimum ATP Rating (A)	Rated Speed (RPM)
			kVA	kW	kVA	kW			
50	3	400/230V	550.0	440.0	601.0	480.8	800	800	1500
60	3	380/220V	558.1	446.5	608.1	486.5	1000	1000	1800
60	3	220/127V	561.6	449.3	611.9	489.5	1600	1600	1800
60	3	480/277V	561.6	449.3	611.9	489.5	800	800	1800

## POWER FACTOR

3 Phase	0.8
1 Phase	1

## MAXIMUM LOAD IMPACT\*

kVA	330.00
kW	264.00

\*With 20% voltage and 10% frequency deviation @ 50Hz, 400V

## ALL RATINGS ARE TO STANDARD REFERENCE CONDITIONS ISO 8528

**Prime:** This rating is for the supply of continuous electrical power, at variable load, in lieu of commercially purchase power. There is no limitation on the annual hours of operation and 10% over load power can be supplied for 1 hour in 12.

**Standby:** This rating is for the supply of continuous electrical power, at variable load, in the event of a utility power failure. No overload is permitted.

"Stage IIIa" models are only emissions compliant at 50Hz Prime Power in accordance with 97-68EC.

## CANOPY/SKID

Lockable Maintenance Access Doors	x
Control Panel Viewing Window	x
Fork Pockets	●
Single Lift Point	x
Rental Sledging Base	x
Bunding	Δ
Open Frame	●
Bund Level Indicator	Δ
50mm Rock Wool Sound Insulation	x
Yellow Paint	x
Red Paint	x
White Paint	x
Standard: ●      Not Available: x      Optional: Δ	

## ALTERNATOR HM355BI

Poles	4
Winding Connections	Star
Insulation	Class H
Enclosure	IP23
Exciter System	Self-excited brushless
Voltage Regulator	AVR (electronic)
Steady State Voltage Regulation	+/- 1.0%
Bearing	Single bearing
Coupling	Flexible disc
Cooling	Direct drive centrifugal blower fan
Coating	Winding Protection Grey

## STARTING SYSTEM

Starter Motor	kW	7.00
Battery Capacity	Ah	75
Number of Batteries		2
Auxiliary Voltage	V	24

## ENGINE

<b>1500 RPM</b>		
Output Rating (PRP)	kW	469.00
Output Rating (Standby)	kW	511.00
<b>1800 RPM</b>		
Output Rating (PRP)	kW	481.00
Output Rating (Standby)	kW	523.00
Manufacturer and Model	Scania DC16-44A(10-27)	
Fuel	Diesel	
Injection	Direct	
Aspiration	Turbo Charged and Aftercooled	
Cylinders	0	
Bore and Stroke	mm	127x154
Displacement	L	15.60
Cooling	Water	
Engine Oil Specification	ACEA E3 - E5	
Compression Ratio	16:1	
Engine Oil Capacity	L	35.00
Coolant Capacity	L	95.00
Governor	Electronic	
Air Filter	Dry	
Engine Oil Consumption	100% Load	0.3 g/kWh

## FUEL SYSTEM

Diesel Specification		EN590
Standard Fuel Tank Capacity	L	740

## FUEL TANK OPTIONS

	Material	Capacity (L)
Standard Tank	Steel	740
Tank Option 1		
Tank Option 2		

## FUEL CONSUMPTION

Load Condition	Unit	Frequency	Consumption
100% Load Prime	L/h	50Hz	109.06
75% Load Prime	L/h		83.90
50% Load Prime	L/h		56.77
100% Load Standby	L/h		119.20
100% Load Prime	L/h	60Hz	109.62
75% Load Prime	L/h		85.57
50% Load Prime	L/h		57.61
100% Load Standby	L/h		119.20

## EXHAUST SYSTEM

Parameter	Unit	Frequency	Value
Maximum Temperature 100% Standby	°C	50Hz	530.00
Exhaust Gas Flow 100% Standby	m <sup>3</sup> /min		0.04
Maximum Allowed Back Pressure	mbar		29.40
Maximum Temperature 100% Standby	°C	60Hz	471.00
Exhaust Gas Flow 100% Standby	m <sup>3</sup> /min		0.05
Maximum Allowed Back Pressure	mbar		29.40
Exhaust Flange Size	mm	160	

## AIR SYSTEM

Parameter	Unit	Frequency	Value
Intake Air Flow 100% Standby	m <sup>3</sup> /h	50Hz	2000.00
Total Cooling Air Flow 100% Standby	m <sup>3</sup> /s		9.80
Alternator Fan Airflow	m <sup>3</sup> /s		1.035
Intake Air Flow 100% Standby	m <sup>3</sup> /h	60Hz	2300.00
Total Cooling Air Flow 100% Standby	m <sup>3</sup> /s		8.50
Alternator Fan Airflow	m <sup>3</sup> /s		1.312

## SOUND PRESSURE (CANOPY ONLY)

Measurement	Frequency	Unit	Value
LpA (7m)	50Hz	dB(A)	N/A
LpA (7m)	60Hz	dB(A)	N/A

## MECHANICAL FEATURES

Cooling Pack	●
Air Filter	●
Mechanical Governor	x
Electronic Governor	●
High Coolant Temperature Sender	x
Low Oil Pressure Sender	x
Advanced Coolant Temperature Sender	●
Advanced Oil Pressure Sender	●
Oil Temperature Sender	●
Water Level Sender	●
Radiator Guards	●
Hot Component Guards	●
Manual Oil Drain Pump (Canopy)	●
Water Jacket Heater	●
Manual Fuel Fill	Δ
Electric Fuel Fill	Δ
Racor Fuel Filter (No Alarm)	Δ
Racor Fuel Filter (With Alarm)	Δ
Pre-Filter with Separator	x
External Spark Arrestor	Δ
Fuel Level Sender	●
Fuel Heater	Δ
External Fuel Fill (Belly Tank)	●
3 Way Fuel Valve and Coupling Nest	Δ
Residential Silencer	Δ
Industrial Silencer	●

Standard: ●      Not Available: x      Optional: Δ

## ELECTRICAL FEATURES

AVR DSR	x
AVR DER	●
Winding Protection Standard	x
Winding Protection Standard +	x
Winding Protection Grey	●
Winding Protection Total	Δ
Winding Protection Total +	Δ
MAUX	●
PMG	Δ
Anti-Condensation Heater	Δ
Miniature Circuit Breaker (Integrated busbar)	x
Moulded Case Circuit Breaker (with integrated busbar)	●
Earth Leakage Protection (Shunt Trip)	●
Synchronisation	Δ
Socket Box (inclusive of heavy duty busbar & micro switch)	x
Preparation for Earth Spike	●
Optional Voltages	Δ
Remote Screen	Δ
Panel Door Micro Switch	Δ
Copper Busbar/Tails	Δ
Emergency Stop Button	●
External Emergency Stop Button	x
Standard: ● Not Available: x Optional: Δ	

## BATTERY FEATURES

Battery Isolator	●
Battery Type	Gel
Battery Size (Ah)	75
Number of Batteries	2
Optional Battery	x
Battery Charger	●
Standard: ● Not Available: x Optional: Δ	

## JCB COMMUNICATION AND CONTROL

KS1	x
CPI	●
CP2	Δ
ATP	Δ
CAN/USB	Δ
CAN/LAN	Δ
CAN RS-232	Δ
Remote Modem	Δ
Standard: ● Not Available: x Optional: Δ	

## SYNCHRONISATION PANEL (OPTION)

DSE8610	Δ
DSE8620	Δ
Standard: ● Not Available: x Optional: Δ	

## WEIGHT AND DIMENSIONS

Length	mm	3600
Width	mm	1460
Height	mm	2090
Shipping Volume (sea ready)	m <sup>3</sup>	10.99
Weight*	Kg	3313.00

\*Standard build with all fluids except fuel

## REFERENCE STANDARDS

JCB Generators are CE certified and conform to the following Directives (subject to a country requiring such standard):

- EN 12100, EN13857, EN60204
- 2006/42/CE Machinery safety
- 2006/95/EC Low voltage
- 2004/108/CE Electromagnetic compatibility
- 2000/14/EC Sound Power Level (amended by 2005/88/EC)
- 97/68/EC Emissions(amended by 2002/88/EC & 2004/26/EC)
- Power according to ISO 8528 and ISO 3046
- Ambient reference conditions 1000mbar, 25°C, 30% relative humidity ISO3046

Information based on standard specification equipment unless otherwise stated.