

GI65QS | Canopy Set

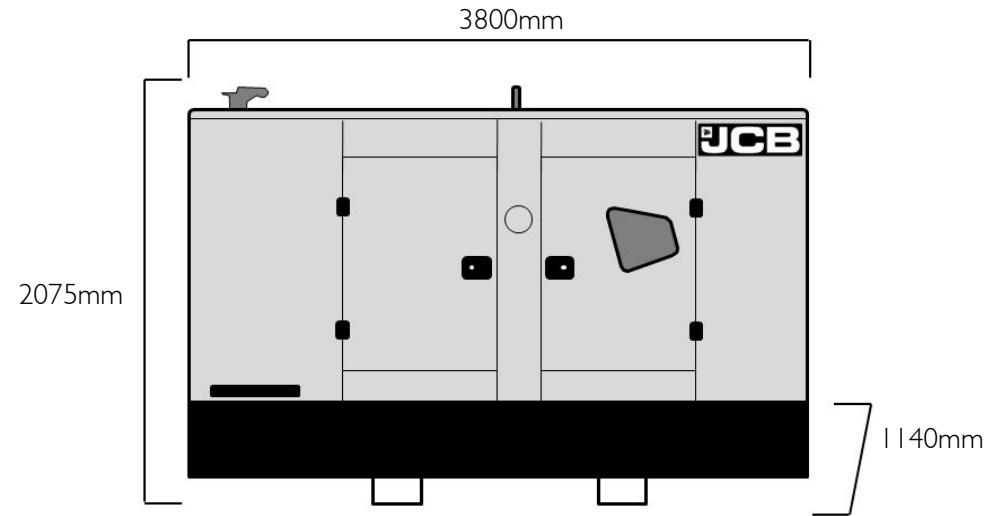

DIESEL GENERATOR

FUEL OPTIMISED

ELECTRICAL

| Frequency (Hz) | Phases | Voltage (V) | Prime | | Standby | | MCB Rating (A) | Minimum ATP Rating (A) | Rated Speed (RPM) |
|----------------|--------|-------------|-------|-------|---------|-------|----------------|------------------------|-------------------|
| | | | kVA | kW | kVA | kW | | | |
| 50 | 3 | 400/230V | 150.0 | 120.0 | 165.0 | 132.0 | 250 | 250 | 1500 |
| 60 | 3 | 380/220V | 150.0 | 120.0 | 165.0 | 132.0 | 250 | 250 | 1800 |
| 60 | 3 | 220/127V | 156.0 | 124.8 | 173.3 | 138.6 | 500 | 500 | 1800 |
| 60 | 3 | 208/120V | 156.0 | 124.8 | 173.3 | 138.6 | 500 | 500 | 1800 |

POWER FACTOR

| | |
|---------|-----|
| 3 Phase | 0.8 |
| 1 Phase | 1 |

MAXIMUM LOAD IMPACT*

| | |
|-----|-------|
| kVA | 90 |
| kW | 72.00 |

*With 20% voltage and 10% frequency deviation @ 50Hz, 400V

ALL RATINGS ARE TO STANDARD REFERENCE CONDITIONS ISO 8528

Prime: This rating is for the supply of continuous electrical power, at variable load, in lieu of commercially purchase power. There is no limitation on the annual hours of operation and 10% over load power can be supplied for 1 hour in 12.

Standby: Standby Power (ESP) is the maximum output available, for up to 200 hours per year, where the average load (variable) does not exceed 70% of the standby power rating. No overload is available.

Stage IIIA Models are only emissions compliant at 50Hz Prime Power in accordance with 97-68EC.

CANOPY/SKID

| | |
|--|---|
| Lockable Maintenance Access Doors | ● |
| Control Panel Viewing Window | ● |
| Fork Pockets | Δ |
| Single Lift Point | Δ |
| Bunding | Δ |
| Open Frame | Δ |
| High Density Fire Retardant Foam | ● |
| Yellow Paint | ● |
| White Paint | Δ |
| Four Point Lift (non CE) | Δ |
| Standard: ● Not Available: x Optional: Δ | |

ALTERNATOR ECP34-2L/4

| | |
|---------------------------------|-------------------------------------|
| Poles | 4 |
| Winding Connections | Star |
| Insulation | Class H |
| Enclosure | IP23 |
| Exciter System | Self-regulating brushless |
| Voltage Regulator | AVR |
| Steady State Voltage Regulation | +/- 1.5% |
| Bearing | Single bearing sealed |
| Coupling | Flexible disc |
| Cooling | Direct drive centrifugal blower fan |
| Coating | Winding Protection Grey |

STARTING SYSTEM

| | | |
|---------------------|----|------|
| Starter Motor | kW | 4.00 |
| Battery Capacity | Ah | 110 |
| Number of Batteries | | 2 |
| Auxiliary Voltage | V | 24 |

ENGINE

| | | |
|------------------------------|-----------|-----------------------|
| 1500 RPM | | |
| Gross Engine Power (PRP) | kW | 145.00 |
| Gross Engine Power (Standby) | kW | 159.50 |
| 1800 RPM | | |
| Gross Engine Power (PRP) | kW | 145.00 |
| Gross Engine Power (Standby) | kW | 159.50 |
| Manufacturer and Model | | JCB 672 TA2G- 145 |
| Fuel | | Diesel |
| Injection | | Direct |
| Aspiration | | Turbo Charged |
| Cylinders | | 6 |
| Bore and Stroke | mm | 106 x 135 |
| Displacement | L | 7.15 |
| Cooling | | Water |
| Engine Oil Specification | | API CH4-SAE 10W40 |
| Compression Ratio | | 16.9 : 1 |
| Engine Oil Capacity | L | 28.00 |
| Coolant Capacity | L | 26.00 |
| Governor | | Electronic |
| Air Filter | | Two stage filtration |
| Engine Oil Consumption | 100% Load | 0.1% of fuel consumed |

FUEL SYSTEM

| | | |
|-----------------------------|---|-------|
| Diesel Specification | | EN590 |
| Standard Fuel Tank Capacity | L | 360 |

FUEL CONSUMPTION

| Load Condition | Unit | Frequency | Consumption |
|-------------------|------|-----------|-------------|
| 100% Load Prime | L/h | 50Hz | 33.4 |
| 75% Load Prime | L/h | | 25.80 |
| 50% Load Prime | L/h | | 17.60 |
| 100% Load Standby | L/h | | 36.10 |
| 100% Load Prime | L/h | 60Hz | 33.80 |
| 75% Load Prime | L/h | | 26.60 |
| 50% Load Prime | L/h | | 18.60 |
| 100% Load Standby | L/h | | 36.40 |

EXHAUST SYSTEM

| Parameter | Unit | Frequency | Value |
|----------------------------------|---------------------|-----------|--------|
| Maximum Temperature 100% Standby | °C | 50Hz | 480.00 |
| Exhaust Gas Flow 100% Standby | m ³ /min | | 25.60 |
| Maximum Allowed Back Pressure | mbar | | 40.00 |
| Maximum Temperature 100% Standby | °C | 60Hz | 420 |
| Exhaust Gas Flow 100% Standby | m ³ /min | | 27.60 |
| Maximum Allowed Back Pressure | mbar | | 50.00 |
| Exhaust Flange Size | mm | 76.5 | |

AIR SYSTEM

| Parameter | Unit | Frequency | Value |
|--|-------------------|-----------|--------|
| Intake Air Flow 100% Standby | Kg/h | 50Hz | 769.00 |
| Total Cooling Air Flow 100% Standby (@ 16 mm H ₂ O Canopy Depression) | m ³ /s | | 7.2 |
| Alternator Fan Airflow | m ³ /s | | 0.32 |
| Intake Air Flow 100% Standby | Kg/h | 60Hz | 889.00 |
| Total Cooling Air Flow 100% Standby (@ 16 mm H ₂ O Canopy Depression) | m ³ /s | | 7.2 |
| Alternator Fan Airflow | m ³ /s | | 0.38 |

MECHANICAL FEATURES

| | |
|--|---|
| Cooling Pack | ● |
| Air Filter | ● |
| Mechanical Governor | x |
| Low Oil Pressure Sender | ● |
| Coolant Temperature Sender | Δ |
| Low Oil Pressure Sensor | Δ |
| Oil Temperature Sender | ● |
| Radiator Guards | ● |
| Hot Component Guards | Δ |
| Manual Oil Drain Pump (Canopy) | Δ |
| Water Jacket Heater | Δ |
| Pre-Filter with Separator | ● |
| Mechanical Fuel Level Indicator (Non CE Only) | Δ |
| Internal Fuel Fill (Belly Tank) | ● |
| 3 Way Fuel Valve with Quick Connector | Δ |
| Residential Silencer | ● |
| Industrial Silencer | x |
| Door Stops | Δ |
| Canopy Bump Stops | Δ |
| Bunded Base | Δ |
| Gravity Oil Drain Pipe | Δ |
| Larger Fuel Filler Neck | Δ |
| Electronic Governor | ● |
| Standard: ● Not Available: x Optional: Δ | |

SOUND PRESSURE (CANOPY ONLY)

| | | | |
|----------|------|-------|----|
| LpA (7m) | 50Hz | dB(A) | 68 |
|----------|------|-------|----|

ELECTRICAL FEATURES

| | |
|---|----------|
| AVR DSR | ● |
| AVR DER | x |
| Winding Protection Standard | x |
| Winding Protection Standard + | x |
| Winding Protection Grey | ● |
| Winding Protection Total | x |
| Winding Protection Total + | x |
| MAUX | ● |
| PMG | x |
| Anti-Condensation Heater | Δ |
| 3 Pole Moulded Case Circuit Breaker | ● |
| 4 Pole Moulded Case Circuit Breaker | Δ |
| Earth Leakage Protection (Shunt Trip) | ● |
| Preparation for Earth Connection | ● |
| Optional Voltages | Δ |
| Synchronisation | Δ (soon) |
| Emergency Stop Button | ● |
| External Emergency Stop Button | ● |
| Fuel Level Sensor | ● |
| 1x63A 3 Phase / 3x32A 1 Phase Socket Box | x |
| 1x63A 3 Phase / 3x32A 1 Phase / 2x16A 1Phase Socket Box | x |
| 1x32A 3 Phase / 2x16A 1 Phase Socket Box | x |
| Standard: ● Not Available: x Optional: Δ | |

BATTERY FEATURES

| | |
|--|------------------|
| Battery Isolator | Δ |
| Battery Type | Sealed Lead Acid |
| Battery Size (Ah) | 110 |
| Number of Batteries | 2 |
| Battery Charger | Δ |
| Standard: ● Not Available: x Optional: Δ | |

JCB COMMUNICATION AND CONTROL

| | |
|--|----------|
| DSE 4510 | x |
| DSE 4520 | ● |
| DSE 7320 | Δ |
| DSE 8610 | Δ (soon) |
| Live Link For Power | ● |
| OPTIONAL CE PACK | |
| EMC Certification | ● |
| Hot Guards | ● |
| Belt Guards | ● |
| Earth Leakage Relay | ● |
| Sound Power Decal | ● |
| EU Declaration for Engine Emissions | ● |
| Complete Machine Declaration of Conformity | ● |
| Standard: ● Not Available: x Optional: Δ | |

WEIGHT AND DIMENSIONS

| | | |
|-----------------------------|----------------|---------|
| Length | mm | 3800 |
| Width | mm | 1140 |
| Height | mm | 2075 |
| Shipping Volume (sea ready) | m ³ | 9.00 |
| Weight* | Kg | 2700.00 |

*Standard build with all fluids except fuel

REFERENCE STANDARDS

JCB Generators are CE certified and conform to the following Directives (subject to a country requiring such standard):

- EN 12100, EN13857, EN60204
- 2006/42/CE Machinery safety
- 2006/95/EC Low voltage
- 2004/108/CE Electromagnetic compatibility
- 2000/14/EC Sound Power Level (amended by 2005/88/EC)
- 97/68/EC Emissions(amended by 2002/88/EC & 2004/26/EC)
- Power according to ISO 8528 and ISO 3046
- Ambient reference conditions 1000mbar, 25°C, 30% relative humidity ISO3046

Information based on standard specification equipment unless otherwise stated.